

We Put You In the Best Position



Ergo Control® Programmable Work Positioner for Heavy Loads

Description

A unique 3-axis programmable work positioner that provides full position flexibility to manage any job, including heavy, large and awkwardly shaped objects.

Application

Ergo Control is ideal for secure positioning of any object for any project, no matter what size or shape. This programmable work positioner offers unlimited applications in any industry and is advantageous in any shop floor or work area.

Ergonomic Benefit

- Eliminate employee strain, fatigue and injury.
- Create a safer and more productive work environment.
- Allow easy access and worker comfort for any job.

Standard Features

- Offers full flexibility to move work to any work positions.
- Adaptable to any work fixtures.
- Always ensures the correct work sequence.
- Easy to program via handheld pendant and to operate via foot pedal. Each time the foot pedal is pressed the work piece is moved to the next programmed position.
- Large program capacity for storage of operations to suit each individual operator and application.
- The "L" shaped rotational arm allows easy access to any work surface, including upside down, in a comfortable work position.
- Unlimited rotation on Y + Z axes .
- Easy to program with quick and easy downloading of any stored program (100 programs). Move to desired position and press the programming button. The position is stored in memory. Repeat the procedure to the last position in the work sequence.
- Short set up time.
- Available in 6 standard load classes: 330, 660, 1650, 3300, 6600 and 13,300 lbs.

Options

- **Pneumatic supply** is provided through arm to the top of the turntable. Used for clamping of fixture, etc.
- **Hand Control** (including security module) allows motion to be changed from hand instead of foot pedal.
- **Dual Arm** expands attachment alternatives.
- **External speed** and directional rotation of turn table (Z-Axis) in programmed position. Useful for welding, etc.
- **Micro Switches** allow motion to be changed directly from the weld gun instead of using foot pedal.
- **Programmable Laser Scanner** is placed in front of machine to stop machine if the operator is within programmed safety field.
- **ErgoCam** allows downloading of machine programs into any Windows based computer for back-up storage.

Application Examples



Technical Information

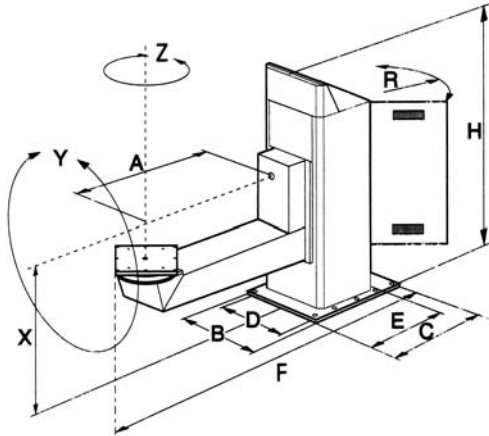

Features	Model 150E	Model 300E	Model 750E	Model 1500E	Model 3000E	Model 6000E
Max. load 3-axis	330 lbs.	660 lbs.	1650 lbs.	3300 lbs.	6600 lbs.	13,300 lbs.
Max. load 2-axis	660 lbs.	1100 lbs.	2200 lbs.	4400 lbs.	8800 lbs.	17,600 lbs.
A. Arm length	19.7"	25.6"	39.4"	55.1"	55.1"	86.7"
B. Base width	23.5"	28"	33.7"	37.8"	65.4"	59.6"
C. Base depth	20"	37.4"	43.3"	51.1"	54.4"	67.0"
D. Width	18.5"	21.9"	28"	31.7"	35.7"	51.0"
E. Depth	23.5"	26.2"	32.5"	36.8"	43.9"	42.6"
F. Total depth	54"	76.8"	101.6"	130.7"	134.6"	185.8"
H. Max height	73"	74"	94.9"	94.9"	102.7"	125.7"
R. Rear cabinet	13.8"	22"	27.6"	31.3"	31.3"	48.9"
X - Vertical travel	17-48.5"	21.3-52.5"	28.3-69.5"	26.6-66.7"	32.2-73"	37-83"
Y - Rotation	unlimited	unlimited	unlimited	unlimited	unlimited	unlimited
Z - Rotation	unlimited	unlimited	unlimited	unlimited	unlimited	unlimited
Lifting speed X	3.1"/sec.	4.9"/sec.	2.3"/sec.	4.6"/sec.	2.3"/sec.	1.6"/sec.
Rotation speed Y	8 rpm	6.5 rpm	3.5 rpm	2.7 rpm	2.7 rpm	1.6 rpm
Rotation speed Z	8 rpm	6.5 rpm	4.8 rpm	2.7 rpm	2.7 rpm	2.7 rpm
Motor effect total kW/A	1/10	2.25/16	4.5/25	7.4/25	8.2/25	10.7/25
Grounding connector	400A	400A	400A	400A	400A	400A
Teach-in programming	yes	yes	yes	yes	yes	yes
Unit Weight	1100 lbs.	2350 lbs.	3100 lbs.	4000 lbs.	6600 lbs.	14,100 lbs.

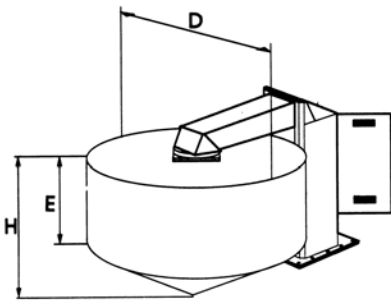

Workpiece vs. Arm Length

Model Dimensions	Model 150E3	Model 300E3	Model 750E3	Model 1500E3	Model 3000E3	Model 6000E3
D	39.4"	51.2"	78.7"	110.2"	110.2"	173.4"
E	47.2"	50.8"	66.5"	49.6"	49.6"	46.5"
H	56.3"	57.7"	78.7"	78.7"	78.7"	94.5"

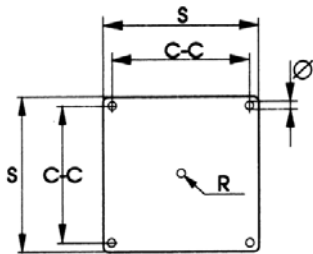

Fixture Mounting Plate

Model Dimensions	Model 150E3	Model 300E3	Model 750E3	Model 1500E3	Model 3000E3	Model 6000E3
S	12.8"	13.8"	19.7"	20.5"	20.5"	31.5"
C-C	11.6"	12.6"	17.3"	17.3"	17.3"	28.4"
O	0.7"	0.7"	1.0"	1.0"	1.0"	1.2"
R	1/4"	1/2"	1/2"	1/2"	1/2"	1/2"

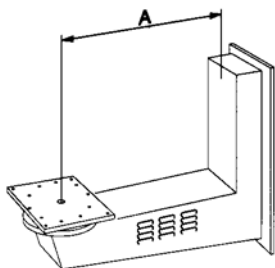

Extended Arm Length (A)

Model Alt.	Model 150E3	Model 300E3	Model 750E3	Model 1500E3	Model 3000E3
1	27.5"	33.5"	47.2"	70.9"	70.9"
2	35.4"	39.4"	55.1"	78.7"	78.7"

